

# PTFE Lined Cast Body Butterfly Valve with Gear Box

## Технические характеристики

### По вопросам продаж и поддержки обращайтесь:

Алматы (7273)495-231	Казань (843)206-01-48	Новокузнецк (3843)20-46-81	Смоленск (4812)29-41-54
Архангельск (8182)63-90-72	Калининград (4012)72-03-81	Новосибирск (383)227-86-73	Сочи (862)225-72-31
Астрахань (8512)99-46-04	Калуга (4842)92-23-67	Омск (3812)21-46-40	Ставрополь (8652)20-65-13
Барнаул (3852)73-04-60	Кемерово (3842)65-04-62	Орел (4862)44-53-42	Сургут (3462)77-98-35
Белгород (4722)40-23-64	Киров (8332)68-02-04	Оренбург (3532)37-68-04	Тверь (4822)63-31-35
Брянск (4832)59-03-52	Краснодар (861)203-40-90	Пенза (8412)22-31-16	Томск (3822)98-41-53
Владивосток (423)249-28-31	Красноярск (391)204-63-61	Пермь (342)205-81-47	Тула (4872)74-02-29
Волгоград (844)278-03-48	Курск (4712)77-13-04	Ростов-на-Дону (863)308-18-15	Тюмень (3452)66-21-18
Вологда (8172)26-41-59	Липецк (4742)52-20-81	Рязань (4912)46-61-64	Ульяновск (8422)24-23-59
Воронеж (473)204-51-73	Магнитогорск (3519)55-03-13	Самара (846)206-03-16	Уфа (347)229-48-12
Екатеринбург (343)384-55-89	Москва (495)268-04-70	Санкт-Петербург (812)309-46-40	Хабаровск (4212)92-98-04
Иваново (4932)77-34-06	Мурманск (8152)59-64-93	Саратов (845)249-38-78	Челябинск (351)202-03-61
Ижевск (3412)26-03-58	Набережные Челны (8552)20-53-41	Севастополь (8692)22-31-93	Череповец (8202)49-02-64
Иркутск (395)279-98-46	Нижний Новгород (831)429-08-12	Симферополь (3652)67-13-56	Ярославль (4852)69-52-93
Россия (495)268-04-70	Киргизия (996)312-96-26-47	Казахстан (7172)727-132	



## PTFE Lined Cast Body Butterfly Valve with Gear Box

### Product Description

#### Features:

1. Small in size, light in weight, easy installation and maintenance.
2. Simple and compact construction, quick 90 degree on-off operation.
3. Minimized operating torque, energy saving.
4. Flow curve tending to straight line, excellent regulation performance.
5. Long service life, standing the test of tens thousands opening/closing operations.
6. Wide selection of materials, applicable to various medium.

#### Performance:

Nominal pressure (MPa)	1.0		1.6
Nominal diameter(mm)	50-1000		50-1000
Test pressure (MPa)	Shell	1.5	2.4
	Seal	1.1	1.76
Applicable temperature	150		
Applicable medium	Fresh water, Sewage, Sea water, Air, Vapor, Food, Medicine, Oils, Acids, Alkalis, etc.		
Operating mode	manual, worm gear, pneumatic, electric, etc.		

#### Standard :

Design & Manufacture	Flange Connection	Face to Face Dimension	Test & Inspection
MSS SP-67 API609	DIN PN10/16/25; ANSI B 16.1 BS4504; ISO PN10/16	API609 ISO5752 series 20	API 598

EN593	JIS B 2212/2213 BS 10 table D; BS 10 table E	BS5155	
-------	---	--------	--

### Material List:

No.	Part Name	Material
1	Body	Carbon Steel/Stainless Steel/Cast Iron/Ductile Iron/ Al-Bronze
2	Disc	Al-Bronze/CF8M/Ductile iron/WCB
3	Seat	EPDM/PEFE/Buna/NBR/Hypalon
4	Stem	Carbon Steel/Stainless Steel314/Stainless Steel316
5	Bushing	PTFE/Lubricating
6	O ring	EPDM/PEFE/Buna/NBR/Hypalon
7	Pin	SS316/SS416/SS304





- Nominal Diameter: DN40-DN800mm
- Nominal Pressure: PN1.0-PN1.6MPa
- Suitable Medium: Various Corrosiveness Medium
- Suitable Temperature: +10°C-150°C



### PTFE Coated Butterfly Valve (Wafer Type)

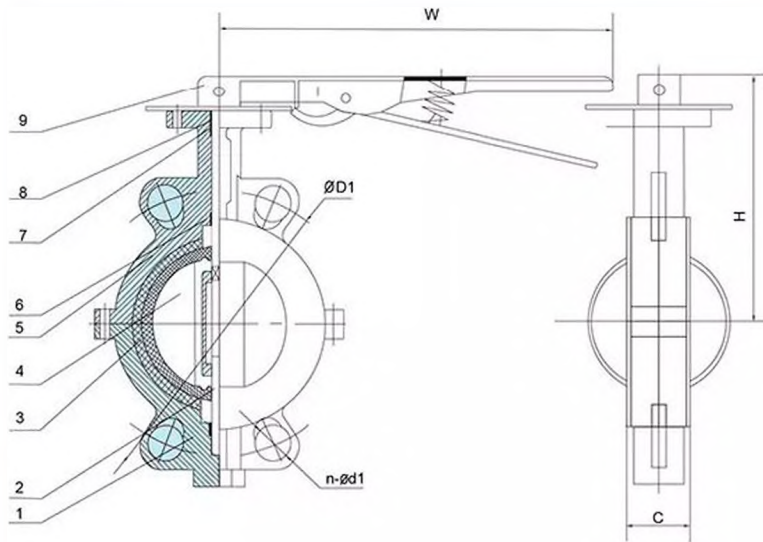

NOMINAL PRESSURE	1.0	MPa
SHELL TEST PRESSURE	1.5	
SEAL TEST PRESSURE	1.1	

#### STANDARD MATERIALS OF MAIN PARTS

ITEM	PART NAME	MA-	STANDARD
1	Lower Valve Body	Wcb	Cf8m
2	Stem	SS416	SS316
3	Seat	Ptfe	Ptfe
4	Disc	Wcb+Ptfe	Cf8m+Ptfe
5	Upper Valve Body	Wcb	CF8M
6	Bushing	Ptfe	Bronze
7	O Ring	Viton	Viton
8	Bushing	Ptfe	Bronze
9	Handle		

#### DIMENSIONS

SIZE		C	H	W	ANSI 150		DIN PN10/16	
IN	DN				D1	n-d1	D1	n-d1
1-1/2	40	40	150	270	98.5	4-15	110	4-18
2	50	43	167	270	120.5	4-19	125	4-18
2-1/2	65	46	170	270	139.5	4-19	145	4-18
3	80	46	170	270	152.5	4-19	160	4(4/8)-18
4	100	52	181	270	190.5	4(8)-19	180	4(8)-18
5	125	56	205	270	216	4(8)-22	210	4(8)-18
6	150	56	219	270	241.5	4(8)-22	240	4(8)-23
8	200	60	268	360	298.5	4(8)-22	295	4(8/12)-23
10	250	68	284	500	362	4(12)-25	350/355	4(12)-23/27
12	300	78	337	500	432	4(12)-25	400/410	4(12)-23/27

**По вопросам продаж и поддержки обращайтесь:**

Алматы (7273)495-231	Казань (843)206-01-48	Новокузнецк (3843)20-46-81	Смоленск (4812)29-41-54
Архангельск (8182)63-90-72	Калининград (4012)72-03-81	Новосибирск (383)227-86-73	Сочи (862)225-72-31
Астрахань (8512)99-46-04	Калуга (4842)92-23-67	Омск (3812)21-46-40	Ставрополь (8652)20-65-13
Барнаул (3852)73-04-60	Кемерово (3842)65-04-62	Орел (4862)44-53-42	Сургут (3462)77-98-35
Белгород (4722)40-23-64	Киров (8332)68-02-04	Оренбург (3532)37-68-04	Тверь (4822)63-31-35
Брянск (4832)59-03-52	Краснодар (861)203-40-90	Пенза (8412)22-31-16	Томск (3822)98-41-53
Владивосток (423)249-28-31	Красноярск (391)204-63-61	Пермь (342)205-81-47	Тула (4872)74-02-29
Волгоград (844)278-03-48	Курск (4712)77-13-04	Ростов-на-Дону (863)308-18-15	Тюмень (3452)66-21-18
Вологда (8172)26-41-59	Липецк (4742)52-20-81	Рязань (4912)46-61-64	Ульяновск (8422)24-23-59
Воронеж (473)204-51-73	Магнитогорск (3519)55-03-13	Самара (846)206-03-16	Уфа (347)229-48-12
Екатеринбург (343)384-55-89	Москва (495)268-04-70	Санкт-Петербург (812)309-46-40	Хабаровск (4212)92-98-04
Иваново (4932)77-34-06	Мурманск (8152)59-64-93	Саратов (845)249-38-78	Челябинск (351)202-03-61
Ижевск (3412)26-03-58	Набережные Челны (8552)20-53-41	Севастополь (8692)22-31-93	Череповец (8202)49-02-64
Иркутск (395)279-98-46	Нижний Новгород (831)429-08-12	Симферополь (3652)67-13-56	Ярославль (4852)69-52-93
Россия (495)268-04-70	Киргизия (996)312-96-26-47	Казахстан (7172)727-132	