

# Awwa API ASTM Manual Double Half Shaft Butterfly Valve

## Технические характеристики

### По вопросам продаж и поддержки обращайтесь:

Алматы (7273)495-231	Казань (843)206-01-48	Новокузнецк (3843)20-46-81	Смоленск (4812)29-41-54
Архангельск (8182)63-90-72	Калининград (4012)72-03-81	Новосибирск (383)227-86-73	Сочи (862)225-72-31
Астрахань (8512)99-46-04	Калуга (4842)92-23-67	Омск (3812)21-46-40	Ставрополь (8652)20-65-13
Барнаул (3852)73-04-60	Кемерово (3842)65-04-62	Орел (4862)44-53-42	Сургут (3462)77-98-35
Белгород (4722)40-23-64	Киров (8332)68-02-04	Оренбург (3532)37-68-04	Тверь (4822)63-31-35
Брянск (4832)59-03-52	Краснодар (861)203-40-90	Пенза (8412)22-31-16	Томск (3822)98-41-53
Владивосток (423)249-28-31	Красноярск (391)204-63-61	Пермь (342)205-81-47	Тула (4872)74-02-29
Волгоград (844)278-03-48	Курск (4712)77-13-04	Ростов-на-Дону (863)308-18-15	Тюмень (3452)66-21-18
Вологда (8172)26-41-59	Липецк (4742)52-20-81	Рязань (4912)46-61-64	Ульяновск (8422)24-23-59
Воронеж (473)204-51-73	Магнитогорск (3519)55-03-13	Самара (846)206-03-16	Уфа (347)229-48-12
Екатеринбург (343)384-55-89	Москва (495)268-04-70	Санкт-Петербург (812)309-46-40	Хабаровск (4212)92-98-04
Иваново (4932)77-34-06	Мурманск (8152)59-64-93	Саратов (845)249-38-78	Челябинск (351)202-03-61
Ижевск (3412)26-03-58	Набережные Челны (8552)20-53-41	Севастополь (8692)22-31-93	Череповец (8202)49-02-64
Иркутск (395)279-98-46	Нижний Новгород (831)429-08-12	Симферополь (3652)67-13-56	Ярославль (4852)69-52-93
Россия (495)268-04-70	Киргизия (996)312-96-26-47	Казахстан (7172)727-132	

# Awwa API ASTM Manual Double Half Shaft Butterfly Valve



## Product Description

Part Name	Material
Body	CI/DI/WCB/SS
Disc	DI/ALB/WCB/MONEL/CF8/CF8M
Stem	SS416/SS304/SS316/WCB
Seat	EPDM/BUNA/NBR/NR/PTFE/HYPALON/VITON/NEOPRENE



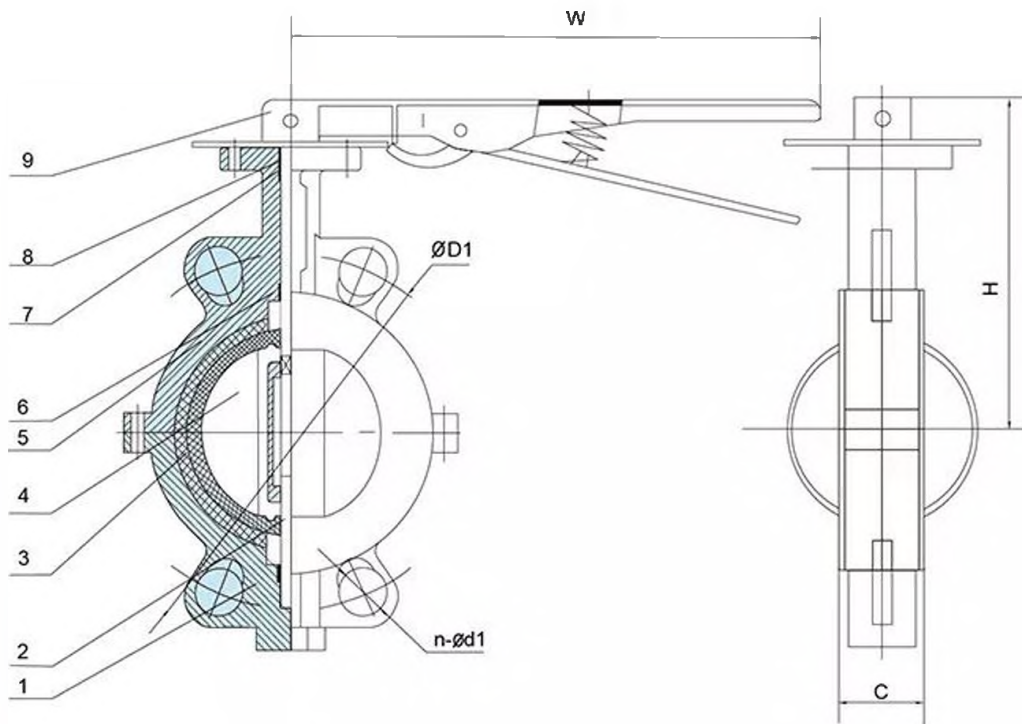

NOMINAL PRESSURE	1.0	MPa
SHELL TEST PRESSURE	1.5	
SEAL TEST PRESSURE	1.1	

#### STANDARD MATERIALS OF MAIN PARTS

ITEM	PART NAME	MA-	STANDARD
1	Lower Valve Body	Wcb	Cf8m
2	Stem	SS416	SS316
3	Seat	Ptfe	Ptfe
4	Disc	Wcb+Ptfe	Cf8m+Ptfe
5	Upper Valve Body	Wcb	CF8M
6	Bushing	Ptfe	Bronze
7	O Ring	Viton	Viton
8	Bushing	Ptfe	Bronze
9	Handle		

#### DIMENSIONS

SIZE		C	H	W	ANSI 150		DIN PN10/16	
IN	DN				D1	n-d1	D1	n-d1
1-1/2	40	40	150	270	98.5	4-15	110	4-18
2	50	43	167	270	120.5	4-19	125	4-18
2-1/2	65	46	170	270	139.5	4-19	145	4-18
3	80	46	170	270	152.5	4-19	160	4(4/8)-18
4	100	52	181	270	190.5	4(8)-19	180	4(8)-18
5	125	56	205	270	216	4(8)-22	210	4(8)-18
6	150	56	219	270	241.5	4(8)-22	240	4(8)-23
8	200	60	268	360	298.5	4(8)-22	295	4(8/12)-23
10	250	68	284	500	362	4(12)-25	350/355	4(12)-23/27
12	300	78	337	500	432	4(12)-25	400/410	4(12)-23/27

## Wafer or Lug Body Styles Stainless steel

One-piece wafer body style or full lug style for terminal service. Both body styles offer bidirectional sealing as standard in conformance, Cast iron and stainless steel can be selected, Customizable product color and logo



## Wide Variety Of Disc Material Choices

Precision machined and hand polished disc to provide a minimum torque and longer seat life. Customizable color material



## Actuator Mounting Flange OR Handle

The top flange is drilled as per EN ISO 5211 to accommodate direct mounting of a wide range of actuators. Operating handles with different materials and colors



## Wide Choice Of Seating Materials

Smooth finished disc flats mate with seat to give a highly efficient primary seal that prevents leakage into the shaft area. Customizable seat material, such as EPDM, NBR, PTFE and so on.



Optional Electric Actuated and Pneumatic Actuated



**По вопросам продаж и поддержки обращайтесь:**

Алматы (7273)495-231	Казань (843)206-01-48	Новокузнецк (3843)20-46-81	Смоленск (4812)29-41-54
Архангельск (8182)63-90-72	Калининград (4012)72-03-81	Новосибирск (383)227-86-73	Сочи (862)225-72-31
Астрахань (8512)99-46-04	Калуга (4842)92-23-67	Омск (3812)21-46-40	Ставрополь (8652)20-65-13
Барнаул (3852)73-04-60	Кемерово (3842)65-04-62	Орел (4862)44-53-42	Сургут (3462)77-98-35
Белгород (4722)40-23-64	Киров (8332)68-02-04	Оренбург (3532)37-68-04	Тверь (4822)63-31-35
Брянск (4832)59-03-52	Краснодар (861)203-40-90	Пенза (8412)22-31-16	Томск (3822)98-41-53
Владивосток (423)249-28-31	Красноярск (391)204-63-61	Пермь (342)205-81-47	Тула (4872)74-02-29
Волгоград (844)278-03-48	Курск (4712)77-13-04	Ростов-на-Дону (863)308-18-15	Тюмень (3452)66-21-18
Вологда (8172)26-41-59	Липецк (4742)52-20-81	Рязань (4912)46-61-64	Ульяновск (8422)24-23-59
Воронеж (473)204-51-73	Магнитогорск (3519)55-03-13	Самара (846)206-03-16	Уфа (347)229-48-12
Екатеринбург (343)384-55-89	Москва (495)268-04-70	Санкт-Петербург (812)309-46-40	Хабаровск (4212)92-98-04
Иваново (4932)77-34-06	Мурманск (8152)59-64-93	Саратов (845)249-38-78	Челябинск (351)202-03-61
Ижевск (3412)26-03-58	Набережные Челны (8552)20-53-41	Севастополь (8692)22-31-93	Череповец (8202)49-02-64
Иркутск (395)279-98-46	Нижний Новгород (831)429-08-12	Симферополь (3652)67-13-56	Ярославль (4852)69-52-93
Россия (495)268-04-70	Киргизия (996)312-96-26-47	Казахстан (7172)727-132	