

Strong Acid Wafer Butterfly Valve PTFE Seat

Технические характеристики

По вопросам продаж и поддержки обращайтесь:

Алматы (7273)495-231	Казань (843)206-01-48	Новокузнецк (3843)20-46-81	Смоленск (4812)29-41-54
Архангельск (8182)63-90-72	Калининград (4012)72-03-81	Новосибирск (383)227-86-73	Сочи (862)225-72-31
Астрахань (8512)99-46-04	Калуга (4842)92-23-67	Омск (3812)21-46-40	Ставрополь (8652)20-65-13
Барнаул (3852)73-04-60	Кемерово (3842)65-04-62	Орел (4862)44-53-42	Сургут (3462)77-98-35
Белгород (4722)40-23-64	Киров (8332)68-02-04	Оренбург (3532)37-68-04	Тверь (4822)63-31-35
Брянск (4832)59-03-52	Краснодар (861)203-40-90	Пенза (8412)22-31-16	Томск (3822)98-41-53
Владивосток (423)249-28-31	Красноярск (391)204-63-61	Пермь (342)205-81-47	Тула (4872)74-02-29
Волгоград (844)278-03-48	Курск (4712)77-13-04	Ростов-на-Дону (863)308-18-15	Тюмень (3452)66-21-18
Вологда (8172)26-41-59	Липецк (4742)52-20-81	Рязань (4912)46-61-64	Ульяновск (8422)24-23-59
Воронеж (473)204-51-73	Магнитогорск (3519)55-03-13	Самара (846)206-03-16	Уфа (347)229-48-12
Екатеринбург (343)384-55-89	Москва (495)268-04-70	Санкт-Петербург (812)309-46-40	Хабаровск (4212)92-98-04
Иваново (4932)77-34-06	Мурманск (8152)59-64-93	Саратов (845)249-38-78	Челябинск (351)202-03-61
Ижевск (3412)26-03-58	Набережные Челны (8552)20-53-41	Севастополь (8692)22-31-93	Череповец (8202)49-02-64
Иркутск (395)279-98-46	Нижний Новгород (831)429-08-12	Симферополь (3652)67-13-56	Ярославль (4852)69-52-93
Россия (495)268-04-70	Киргизия (996)312-96-26-47	Казахстан (7172)727-132	



Strong Acid Wafer Butterfly Valve PTFE Seat

Product Description

Wafer Butterfly Valve with Tongue and Groove Seat, PN10/16, 150LB

Size: DN50-DN600

Flange: DIN, BS, ISO, ANSI, AS, JIS

Face to Face: API609, BS5155, DIN3202, ISO5752

Top Flange: ISO 5211

Normal Pressure: PN1.0/1.6Mpa(150/200PSI)

Body: Cast Iron/Ductile Iron/WCB/ALB/CF8/CF8M

Disc: DI/ALB/CF8M/CF8/Hastelloy Alloy/Monel

Stem: SS416/304/316/431

Seat: Hypalon/EPDM/Neoprene/NBR/Viton

Suitable Temperature: -45C to 150° C

Features:

1. Structure simple compact, the weight is light, 90° revolves, the switch is rapid
2. Designs reasonably, the assembling and dismantling is easy, to be advantageous for the service
3. Uses the eccentric structure, reduces the seal packing collar the friction, lengthens the valve service life
4. Completely seals, divulges for zeroMaterials

STANDARD MATERIAL OF MAIN PARTS

NO.	PART	MATERIAL
1	Body	Cast Iron, Ductile Iron, Carbon Steel, Stainless Steel
2	Seat	NBR,EPDM, Viton,Neoprene,HYPALON,Silicon
3	Shaft	Stainless Steel416,316,304
4	Disc	Ductile Iron+Ni,CF8,CF8M,Bronze
5	Pin	Stainless Steel
6	Bushing	PTFE,Bronze
7	O-Ring	NBR,EPDM



Wafer Butterfly Valve (Two Holes With Tongue-And-Groove Seat)

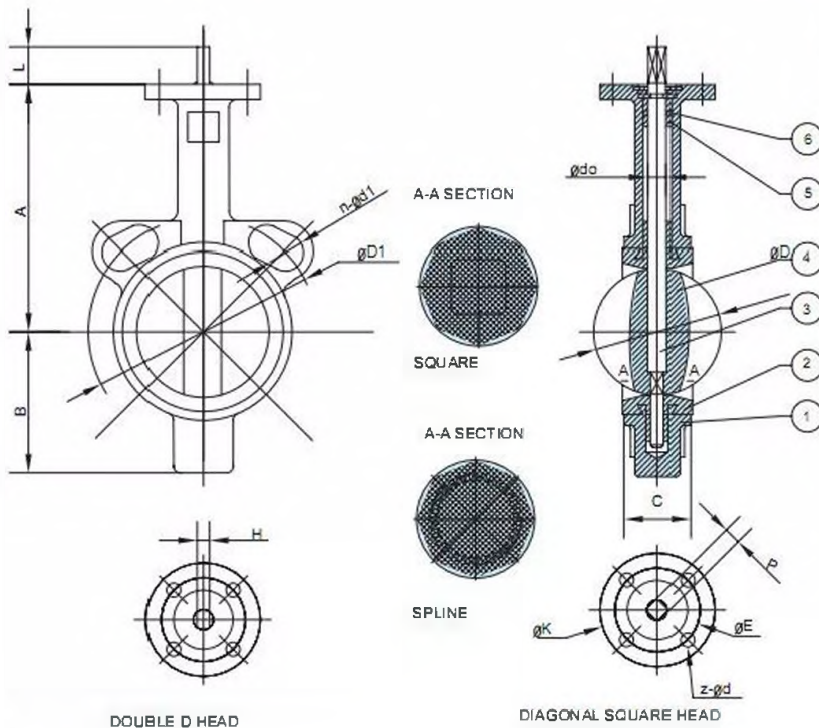

- Type:
Wafer
- Face to Face:
API609, BS5155, DIN3202, ISO5752
- Flange:
DIN, BS, UNI, ISO, ANSI, AS, JIS
- Mounting Flange:
ISO5211

STANDARD MATERIALS OF MAIN PARTS

NO.	PART	MATERIALS
1	Body	Cast iron, Ductile iron, Carbon steel, Stainless Steel
2	seat	NBR, EPDM, Viton, Neoprene, Hypalon, Silicon
3	Shaft	Stainless Steel 416, 316, 304
4	Disc	Ductile iron+Ni (Nylon/Epoxy) CF8, CF8M, Bronze
5	Bushing	PTFE
6	O Ring	NBR, EPDM

DIMENSIONS

SIZE	IN	DN	A	B	C	D	L	d0	P	H	UPPER FLANGE			ANSI 150		DIN PN 10/16		JIS 10K	
											K	E	Z-d	D1	n-d1	D1	n-d1	D1	n-d1
2	50	161	80	42.4	56	32	14.3/12.6	11.9	10	90	70	4-9	120.5	4-19	125	4-18	120	4-19	
2-1/2	65	175	89	45.8	67.87	32	14.3/12.6	11.9	10	90	70	4-9	139.5	4-19	145	4-18	140	4-19	
3	80	181	95	45.8	80.5	32	14.3/12.6	11.9	10	90	70	4-9	152.5	4-19	160	4-18	150	8-19	
4	100	200	114	52	108.1	32	15.77	11	12	90	70	4-9	190.5	8-19	180	8-18	175	8-19	
5	125	213	127	55	131	32	18.92	14	14	90	70	4-9	216	8-22	210	8-18	210	8-23	
6	150	226	138	55	153.3	32	18.92	14	14	90	70	4-9	241.5	8-22	240	8-23	240	8-23	
8	200	280	175	61	204.8	45	22.1	17	17	125	102	4-12	298.5	8-22	295	8-12-23	290	12-23	
10	250	292	203	67.2	255.4	45	28.45	22	22	125	102	4-12	362	12-25	360/355	12-23/27	355	12-25	
12	300	337	242	77	308.8	45	31.6	22	22	140	102	4-12	432	12-25	400/410	12-23/27	400	18-25	



- Working Pressure:
PN16(200PSI)
- Application:
HVAC, Water Supply & Sewage,
Food & Beverage, Chemical/
petrochemical/processing, Power and
Utilities, Paper and Pulp, Ship Building

По вопросам продаж и поддержки обращайтесь:

Алматы (7273)495-231	Казань (843)206-01-48	Новокузнецк (3843)20-46-81	Смоленск (4812)29-41-54
Архангельск (8182)63-90-72	Калининград (4012)72-03-81	Новосибирск (383)227-86-73	Сочи (862)225-72-31
Астрахань (8512)99-46-04	Калуга (4842)92-23-67	Омск (3812)21-46-40	Ставрополь (8652)20-65-13
Барнаул (3852)73-04-60	Кемерово (3842)65-04-62	Орел (4862)44-53-42	Сургут (3462)77-98-35
Белгород (4722)40-23-64	Киров (8332)68-02-04	Оренбург (3532)37-68-04	Тверь (4822)63-31-35
Брянск (4832)59-03-52	Краснодар (861)203-40-90	Пенза (8412)22-31-16	Томск (3822)98-41-53
Владивосток (423)249-28-31	Красноярск (391)204-63-61	Пермь (342)205-81-47	Тула (4872)74-02-29
Волгоград (844)278-03-48	Курск (4712)77-13-04	Ростов-на-Дону (863)308-18-15	Тюмень (3452)66-21-18
Вологда (8172)26-41-59	Липецк (4742)52-20-81	Рязань (4912)46-61-64	Ульяновск (8422)24-23-59
Воронеж (473)204-51-73	Магнитогорск (3519)55-03-13	Самара (846)206-03-16	Уфа (347)229-48-12
Екатеринбург (343)384-55-89	Москва (495)268-04-70	Санкт-Петербург (812)309-46-40	Хабаровск (4212)92-98-04
Иваново (4932)77-34-06	Мурманск (8152)59-64-93	Саратов (845)249-38-78	Челябинск (351)202-03-61
Ижевск (3412)26-03-58	Набережные Челны (8552)20-53-41	Севастополь (8692)22-31-93	Череповец (8202)49-02-64
Иркутск (395)279-98-46	Нижний Новгород (831)429-08-12	Симферополь (3652)67-13-56	Ярославль (4852)69-52-93
Россия (495)268-04-70	Киргизия (996)312-96-26-47	Казахстан (7172)727-132	