

Grooved end butterfly valve

Технические характеристики

По вопросам продаж и поддержки обращайтесь:

Алматы (7273)495-231	Казань (843)206-01-48	Новокузнецк (3843)20-46-81	Смоленск (4812)29-41-54
Архангельск (8182)63-90-72	Калининград (4012)72-03-81	Новосибирск (383)227-86-73	Сочи (862)225-72-31
Астрахань (8512)99-46-04	Калуга (4842)92-23-67	Омск (3812)21-46-40	Ставрополь (8652)20-65-13
Барнаул (3852)73-04-60	Кемерово (3842)65-04-62	Орел (4862)44-53-42	Сургут (3462)77-98-35
Белгород (4722)40-23-64	Киров (8332)68-02-04	Оренбург (3532)37-68-04	Тверь (4822)63-31-35
Брянск (4832)59-03-52	Краснодар (861)203-40-90	Пенза (8412)22-31-16	Томск (3822)98-41-53
Владивосток (423)249-28-31	Красноярск (391)204-63-61	Пермь (342)205-81-47	Тула (4872)74-02-29
Волгоград (844)278-03-48	Курск (4712)77-13-04	Ростов-на-Дону (863)308-18-15	Тюмень (3452)66-21-18
Вологда (8172)26-41-59	Липецк (4742)52-20-81	Рязань (4912)46-61-64	Ульяновск (8422)24-23-59
Воронеж (473)204-51-73	Магнитогорск (3519)55-03-13	Самара (846)206-03-16	Уфа (347)229-48-12
Екатеринбург (343)384-55-89	Москва (495)268-04-70	Санкт-Петербург (812)309-46-40	Хабаровск (4212)92-98-04
Иваново (4932)77-34-06	Мурманск (8152)59-64-93	Саратов (845)249-38-78	Челябинск (351)202-03-61
Ижевск (3412)26-03-58	Набережные Челны (8552)20-53-41	Севастополь (8692)22-31-93	Череповец (8202)49-02-64
Иркутск (395)279-98-46	Нижний Новгород (831)429-08-12	Симферополь (3652)67-13-56	Ярославль (4852)69-52-93
Россия (495)268-04-70	Киргизия (996)312-96-26-47	Казахстан (7172)727-132	

Grooved end butterfly valve



Product Description

Features:

1. Small in size, light in weight, easy installation and maintenance.
2. Simple and compact construction, quick 90 degree on-off operation.
3. Minimized operating torque, energy saving.
4. Flow curve tending to straight line, excellent regulation performance.
5. Long service life, standing the test of tens thousands opening/closing operations.
6. Wide selection of materials, applicable to various medium.

Performance:

Nominal pressure (MPa)		1.0	1.6
Nominal diameter(mm)		50-300	50-300
Test pressure	Shell	1.5	2.4
(MPa)	Seal	1.1	1.76
Applicable temperature		150	
Applicable medium		Fresh water, Sewage, Sea water, Air, Vapor, Food, Medicine, Oils, Acids, Alkalis, etc.	
Operating mode		manual, worm gear, pneumatic, electric, etc.	

Standard:

Design & Manufacture	Flange Connection	Face to Face	Test & Inspection
----------------------	-------------------	--------------	-------------------

		Dimension	
MSS SP-67 API609 EN593	DIN PN10/16/25; ANSI B 16.1 BS4504; ISO PN10/16 JIS B 2212/2213 BS 10 table D; BS 10 table E	API609 ISO5752 series 20 BS5155	API 598

Material List:

No.	Part Name	Material
1	Body	Carbon Steel/Stainless Steel/Cast Iron/Ductile Iron/ Al-Bronze
2	Disc	Al-Bronze/CF8M/Ductile iron/WCB
3	Seat	EPDM/PEFE/Buna/NBR/Hypalon
4	Stem	Carbon Steel/Stainless Steel314/Stainless Steel316
5	Bushing	PTFE/Lubricating
6	O ring	EPDM/PEFE/Buna/NBR/Hypalon



Grooved End Butterfly Valve

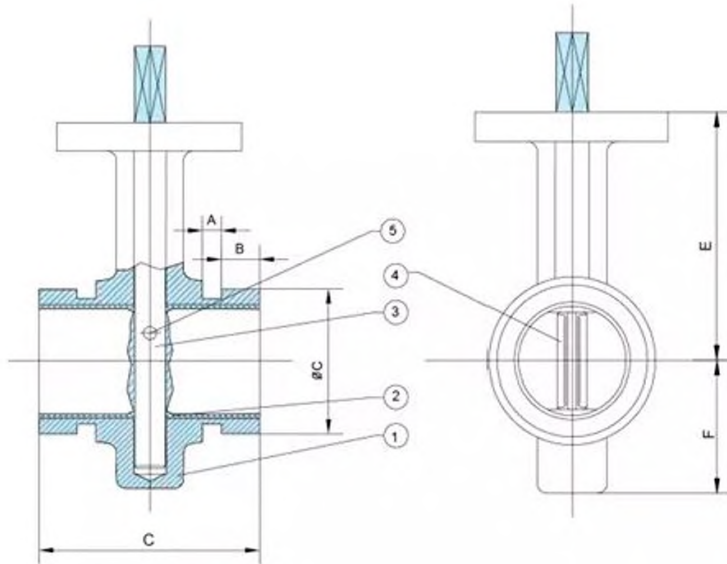

STANDARD MATERIALS OF MAIN PARTS

NO	PART	MATERIAL
1	Body	Cast Iron, Ductile Iron
2	Seat	NBR, EPDM
3	Shaft	Stainless Steel 416, 316, 304
4	Disc	Ductile Iron+Ni, CF8, CF8M
5	Pin	Stainless Steel

DIMENSIONS

in	SIZE		A	B	C	L	E	F
	DN							
2	50		8	16	60	92	100	53
2-1/2	65		8	16	76	102	108	61
3	80		8	16	89	102	114	68
4	100		10	16	114	116	136	85
5	125		10	16	141	125	162	99
6	150		10	16	165	125	174	111
8	200		11	19	219	138	230	145



- Type: Grooved
- Flange: DIN, BS, UNI, ISO, ANSI
- Mounting Flange: ISO 5211

- Working Pressure: PN16(200PSI)
- Application: Water works, Public facilities, Building Industry, Petroleum, Chemical, Steel, Metallurgy, Paper Making Industry, Foods, Beverage



По вопросам продаж и поддержки обращайтесь:

Алматы (7273)495-231	Казань (843)206-01-48	Новокузнецк (3843)20-46-81	Смоленск (4812)29-41-54
Архангельск (8182)63-90-72	Калининград (4012)72-03-81	Новосибирск (383)227-86-73	Сочи (862)225-72-31
Астрахань (8512)99-46-04	Калуга (4842)92-23-67	Омск (3812)21-46-40	Ставрополь (8652)20-65-13
Барнаул (3852)73-04-60	Кемерово (3842)65-04-62	Орел (4862)44-53-42	Сургут (3462)77-98-35
Белгород (4722)40-23-64	Киров (8332)68-02-04	Оренбург (3532)37-68-04	Тверь (4822)63-31-35
Брянск (4832)59-03-52	Краснодар (861)203-40-90	Пенза (8412)22-31-16	Томск (3822)98-41-53
Владивосток (423)249-28-31	Красноярск (391)204-63-61	Пермь (342)205-81-47	Тула (4872)74-02-29
Волгоград (844)278-03-48	Курск (4712)77-13-04	Ростов-на-Дону (863)308-18-15	Тюмень (3452)66-21-18
Вологда (8172)26-41-59	Липецк (4742)52-20-81	Рязань (4912)46-61-64	Ульяновск (8422)24-23-59
Воронеж (473)204-51-73	Магнитогорск (3519)55-03-13	Самара (846)206-03-16	Уфа (347)229-48-12
Екатеринбург (343)384-55-89	Москва (495)268-04-70	Санкт-Петербург (812)309-46-40	Хабаровск (4212)92-98-04
Иваново (4932)77-34-06	Мурманск (8152)59-64-93	Саратов (845)249-38-78	Челябинск (351)202-03-61
Ижевск (3412)26-03-58	Набережные Челны (8552)20-53-41	Севастополь (8692)22-31-93	Череповец (8202)49-02-64
Иркутск (395)279-98-46	Нижний Новгород (831)429-08-12	Симферополь (3652)67-13-56	Ярославль (4852)69-52-93
Россия (495)268-04-70	Киргизия (996)312-96-26-47	Казахстан (7172)727-132	